

REVISION

REV	DATE	DESCRIPTION
△	9/03/20	INITIAL

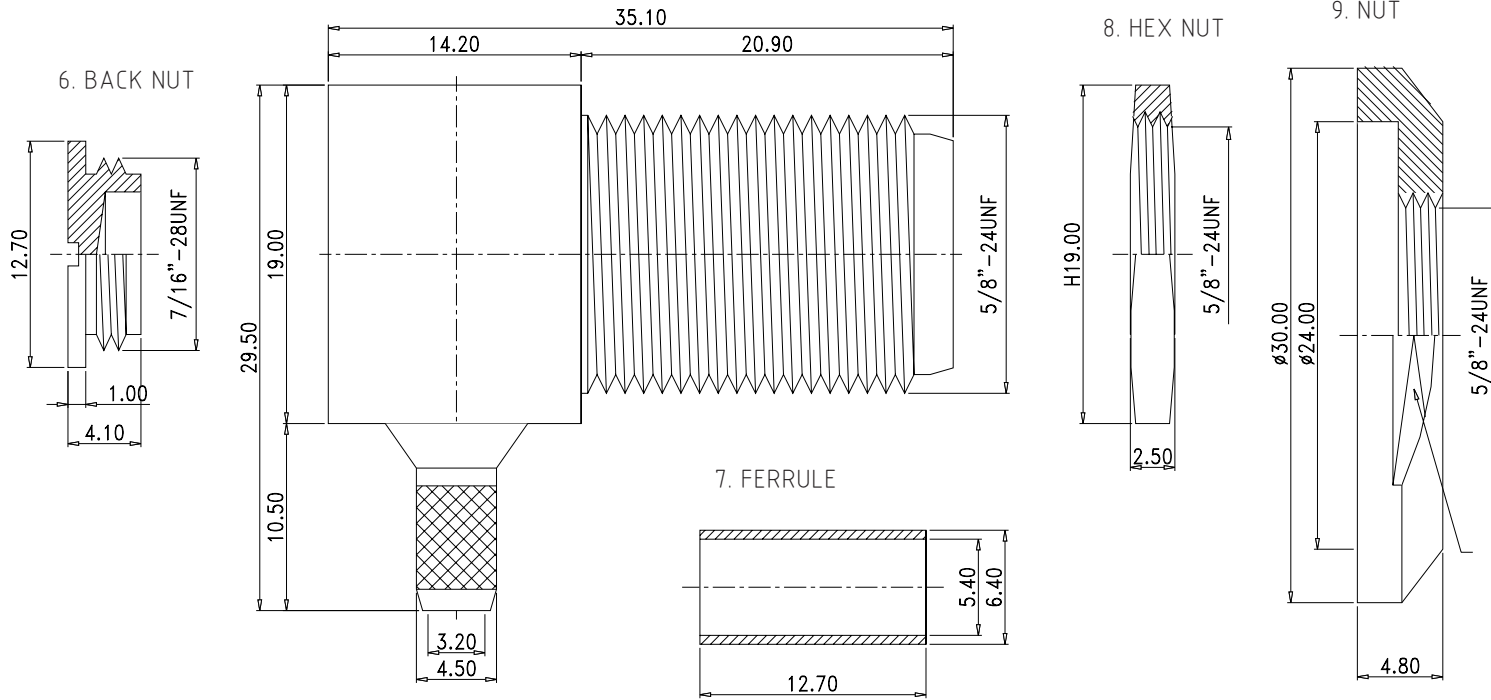

9.	NUT	BRASS	1	NICKEL
8.	HEX NUT	BRASS	1	NICKEL
7.	FERRULE	BRASS	1	NICKEL
6.	BACK NUT	BRASS	1	NICKEL
5.	INSULATION 2	DELRIN	1	NONE
4.	INSULATION 1	DELRIN	1	NONE
3.	PIN	BRASS	1	GOLD
2.	BARREL	BRASS	1	NICKEL
1.	BODY	BRASS	1	NICKEL
NO.	DESCRIPTION	MATERIAL	Q'TY	FINISH

UNITS	SCALE	SIZE	TOLERANCE	DRAWN BY:	CHECKED BY:	CAD FILE
[in] mm	NTS	A	.X +/- 0.2 .XX +/- 0.1 .XXX +/- 0.05 ANGLE +/- 0.5			17-05F-DGN
SHEET 1 OF 1				PROPRIETARY AND CONFIDENTIAL THE INFORMATION IN THIS DRAWING IS THE SOLE PROPERTY OF TCC INDUSTRIES INC. ANY REPRODUCTION IN PARTS OR AS A WHOLE WITHOUT THE WRITTEN PERMISSION OF TCC INDUSTRIES INC. IS PROHIBITED.		

DESCRIPTION
UHF, Jack/Female, Right Angle, Twist-on, for TCC Cable Group F



TCC INDUSTRIES INC.
 7050 Village Drive unit E, Buena Park, CA 90621-2282
 Tel. 714.523.8885 - FAX. 714.562.0888
 E-Mail: info@tccinc.com Website: www.tccinc.com